

FT 046.0325.25

cable winder with powder coated sheet steel plates, 2-fold ball beared, spring catch as hose locking device, with 25m cable H07RN-F 3x2,5, with 3-pole brush slip ring 25A, without plug connector

Order-No.	Weight
631 31 325	29.30 kg 64.70 lb

Measures in mm/inch

A: 460 / 18,11	G: 247 / 9,72	3,94
B: 320 / 12,6	H: 130 / 5,12	N: 80 / 3,15
C: 543 / 21,38	J: 320 / 12,6	O: 10 / 0,39
D: 150 / 5,91	K: 50 / 1,97	P: 212 /
E: 120 / 4,72	L: 143 / 5,63	8,35
F: 8 / 0,31	M: 100 /	

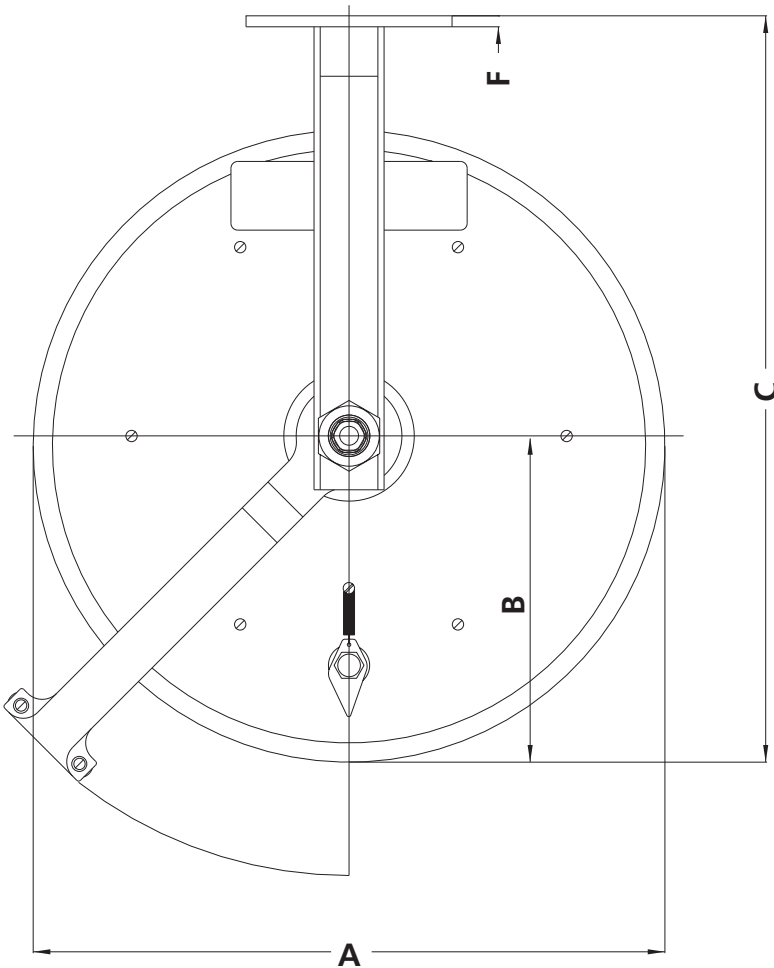
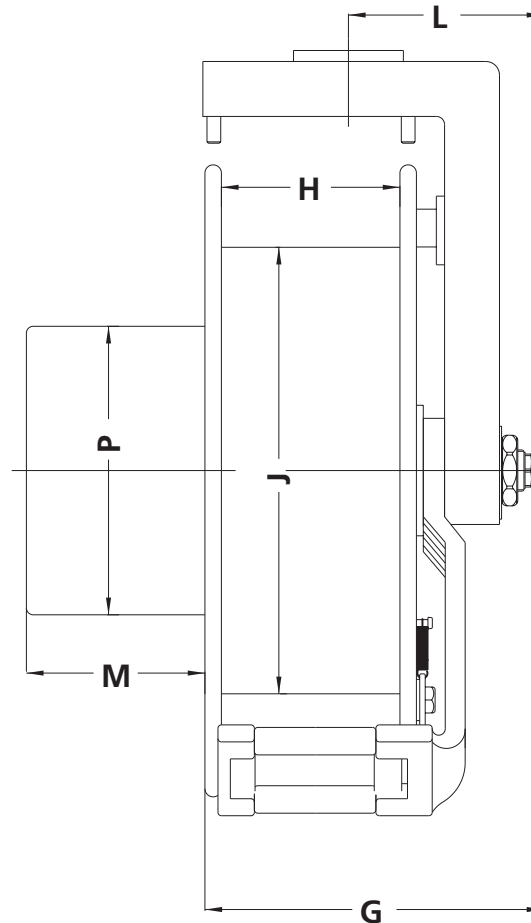

Schill GmbH & Co. KG
Bruckstr. 44
70734 Fellbach/Germany

Phone: +49 (0) 711 57 88 07-0
Fax: +49 (0) 711 57 88 07-44
info@schill.de
www.schill.de